

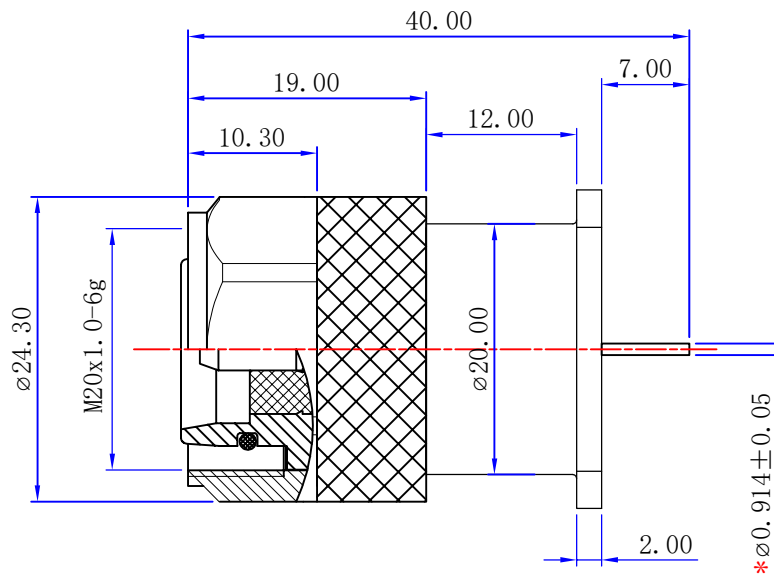

Product NO.		RHT-644-0017		
ISSUE	DESCRIPTION	DWN	DATE	APPROVEN
RI.0	First issue	Gavin	2020/12/22	JIM. KING

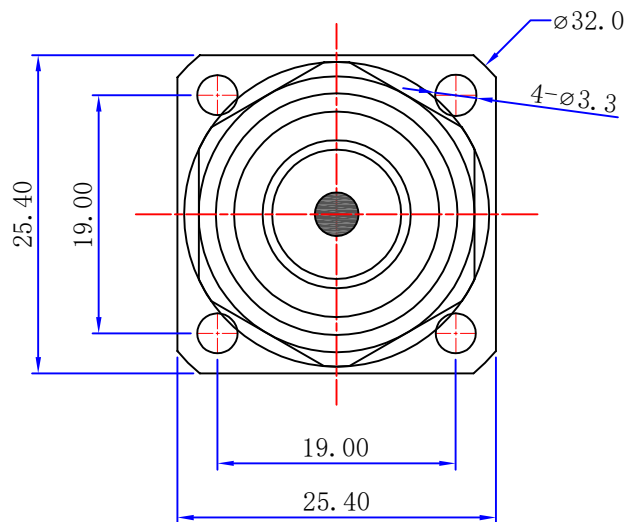

Material & Finishing:

1. Center condutor: Brass, Silver Plating
2. Insulators: PTFE
3. Body : Brass, Ternary alloy Plating
4. O-Ring: Rubber, red

Electrical Data:

1. Impedance: 50 Ohms
2. Frequency: 0~6GHz
3. VSWR: ≤1.15(0-3GHz)
4. Proof Voltage : 2500 Veff
5. Contact Resistance:  
Center Contact:  $\pm 1.0m\Omega$   
Outer Contact :  $\pm 1.0m\Omega$

-TOLERANCES- UNLESS OTHERWISE SPECIFIED	<b>RENHOTEC GROUP</b>				
	PART DESCRIPTION: 4.3-10 Male For PCB				
UNLESS OTHERWISE SPECIFIED TOLERANCES FOR MILLIMETERS ARE: 0.5 - 8mm ± 0.20mm 8 - 30mm ± 0.25mm 30 - 120mm ± 0.30mm	Appr: JIM. KING	P/N: RHT-644-0017			
Check:	Date	Scale	Unit	Type	Page
Draw: Gavin	2020. 12. 22	Free	MM	Z	1/1