

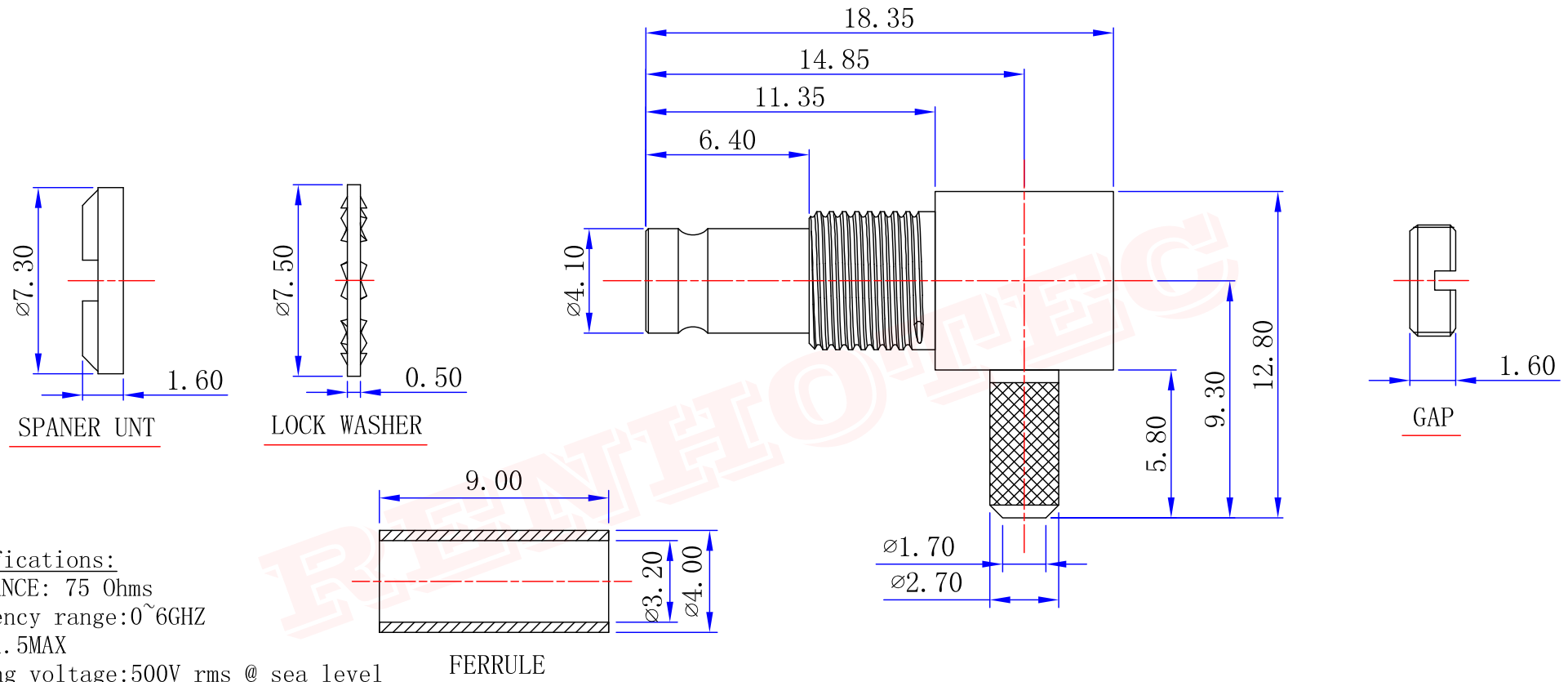

Product NO.		RHT-618-0203		
ISSUE	DESCRIPTION	DWN	DATE	APPROVEN
Frist	First issue	Gavin	2018/06/13	JIM. KING



**Specifications:**  
 IMPEDANCE: 75 Ohms  
 Frequency range: 0~6GHZ  
 VSWR: 1.5MAX  
 Working voltage: 500V rms @ sea level  
 Insulation resistance: 5000 Ohms min  
 Temperature range: -55°C TO +155°C  
 Relative temperature: ≤95% (40° C ± 2° C)

7	GAP	BRASS	GOLD	1
6	FERRULE	COPPER	GOLD	1
5	SPANNER NUI	BRASS	GOLD	1
4	LOCK WASHER	BRASS	NICKEL	1
3	CONTACT PIN	BER. COPPER	GOLD	1
2	INSULATOR	PTFE	NATURAL	1
1	BODY	BRASS	GOLD	1
	DESCRIPTION	MATERIAL	FINISH	QTY

-TOLERANCES- UNLESS OTHERWISE SPECIFIED  UNLESS OTHERWISE SPECIFIED TOLERANCES FOR MILLIMETERS ARE: 0.5 - 8mm ± 0.10mm 8 - 30mm ± 0.15mm 30 - 120mm ± 0.20mm	<b>RENHOTEC GROUP</b> <a href="http://www.renhotec.com">www.renhotec.com</a>	
	PART DESCRIPTION: R/A 1.0-2.3 JACK FOR RG179 CABLE P/N: RHT-618-0203	
Appr: JIM. KING Check: Draw: Gavin	Date: 2018.06.13 Scale: Free Unit: MM	Type: Z Page: 1/1