

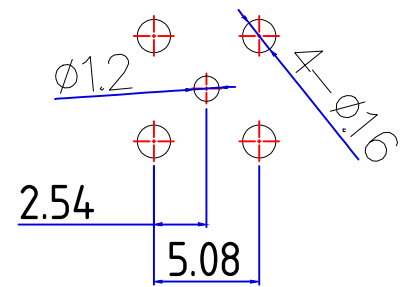

Customer NO:		DOSIN-807-0040		
REV	DESCRIPTION	DWN	DATE	APPROVEN
A	First issue	Mr. CHEN	2017/08/02	John kine
B				

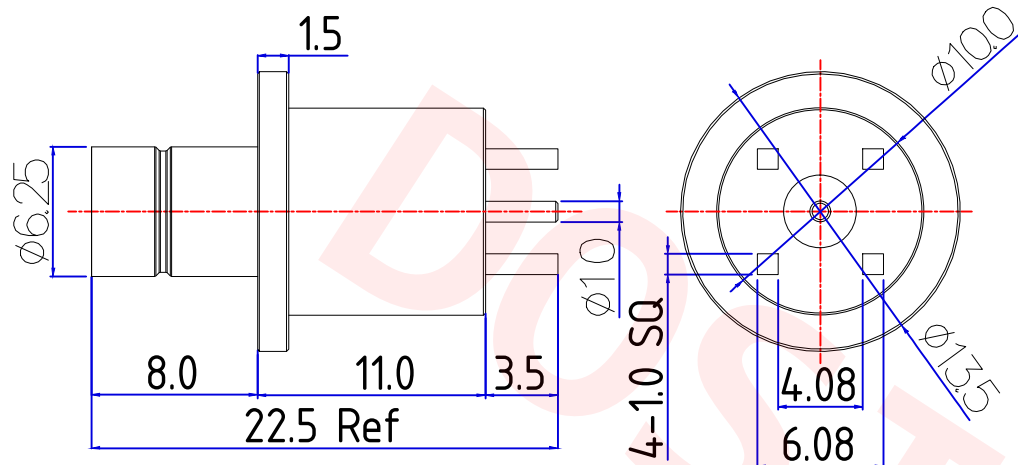

Recommended PCB Layout

**Electrical :**

- Impedance : 75 ohm
- Frequency Range : 0~3 GHz .
- Voltage Rating : 500 V rms.
- Insulator Resistance : 5GW
- Dielectric Withstanding Voltage : 1500 V rms .
- Contact Resistance : Center Contact 3mW.
- Outer Contact 2.5mW.
- Temperature Range : -65°C to 165°C

**Mechanical :**

Material : Snap-on Coupling.

8				
7				
6				
5				
4				
3	CONTACT PIN	BRASS	GOLD	1
2	INSULATOR	TEFLON	WHITE	1
1	BODY	BRASS	GOLD	1
	DESCRIPTION	MATERIAL	FINISH	QTY

NOTE:

DRAWN  
Zelin. CHEN

CHECKED

APPROVALS  
John

Tolerance	X. ±0.15
	X. X ±0.10
	X. XX ±0.05
	Angular ±5°
View	
UNIT	MM
SCALE	1:1

**DOSIN** Dosin Industrial (HK) Co. Ltd  
 东莞市德索五金电子制品有限公司  
 Dosin Hardware Electronics Co., Ltd

E-mail: dosin2005@163.com  
 dosin2005@dosin-china.com  
 Web: http://www.dosinconn.com  
 TEL: (0086) 769-81153906  
 FAX: (0086) 769-81875836

Name: BNC (BT43) S/T Jack PCB Mount Type (75OHM)

SIZE A Product NO. DOSIN-807-0040 REV A

DateTime 2017/08/02 CAD FILE H/company drawings/BD SHEET: 1 OF 1