

Product NO.		DOSIN-807-0001		
REV	DESCRIPTION	DWN	DATE	APPROVEN
A	First issue	JIM	2010/02/03	John kine

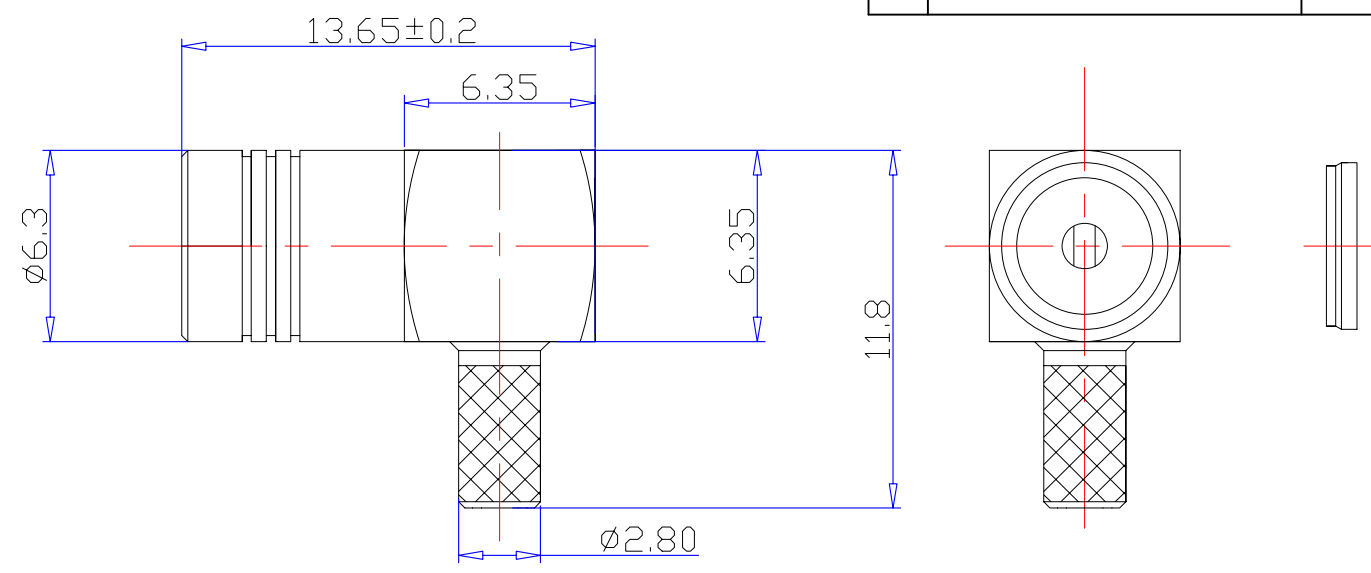

Specification:

VSWR:1.3MAX
 Frequency range:DC~3G
 Working Voltage:500V rms @ sea level
 Insulation resistance:5000 Ohms min
 Temperature range:-55°C TO +155°C
 Relative temperature:≤95%(40° C±2° C)
 Drawings products are in line with ROHS standards.

1	INSULATOR	PTFE	WHITE	1	NOTE:	Tolerance	0-6	±0.2	Dosin Industrial(H.K)Co.Ltd 东莞市德索五金电子制品有限公司 Dosin Hardware Electronics Co.,Ltd E-mail:dosin2005@163.com dosin2005@dosin-china.com Web:http://www.china-guan.com TEL:(0086)769-81153906 FAX:(0086)769-81875836
2	CHMPING	BRASS	NICKEL	1			6-30	±0.3	
3	SHELL	BRASS	GOLD	1			30-120	±0.5	
4	PIN	BRASS	GOLD	1			Angular	±2°	
5	BODY	BRASS	GOLD	1					
6					DRAWN	2012/04/10	View		Name: SMB CONNECTOR
7					Zelin. Zhang				
8					CHECKED		UNIT	MM	SIZE A Product NO. DOSIN-807-0001 REV A
9							SCALE	1:1	
10					APPROVALS		DateTime	2012/04/10	CAD FILE D/company drawings/BD SHEET: 1 OF 1
NO	Component Number	Material	Finish	QTY	John Kine	12/04.2012			