

螺牙段

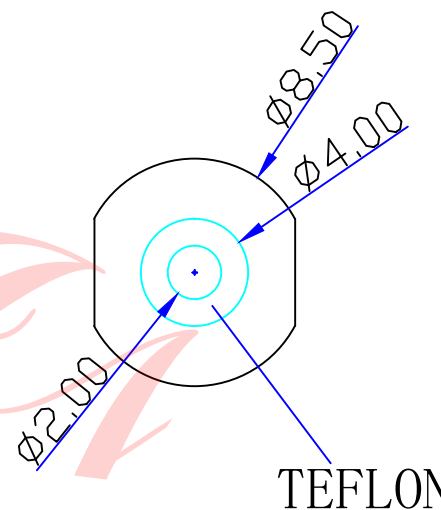
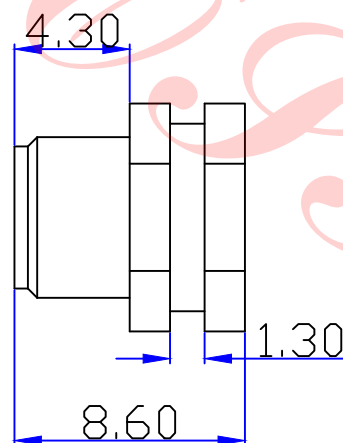
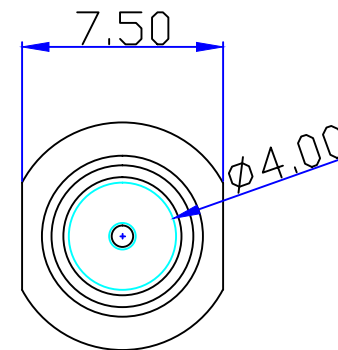
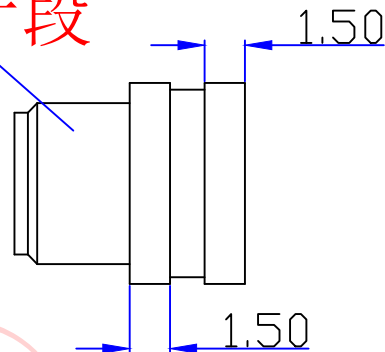

Specifications:

IMPEDANCE: 50 Ohms

Frequency range: 0~6GHZ

VSWR: 1.5MAX

Working voltage: 500V rms @ sea level

Insulation resistance: 5000 Ohms min

Temperature range: -65°C TO +165°C

Relative temperature: ≤95% (40° C ± 2° C)

1	Body	Brass	GOLD
2	Insulator	TEFLON	White
3	CONTACT PIN	Brass	GOLD
4			
5			
6			
7			
8			
9			
10			
NO	Component Number	Material	Finish

NOTE:	
DRAWN	2017/3/14
Zelin. CHEN	
CHECKED	
APPROVALS	14/3. 2017
John Kine	

Tolerance	X. ±0.15
	X.X ±0.10
	X.XX ±0.05
	Angular ±5°
View	
UNIT	MM
SCALE	1:1

<b>Dosing Industrial (H.K) Co. Ltd</b> 东莞市德索五金电子制品有限公司 Dosing Hardware Electronics Co., Ltd		E-mail: dosin2005@163.com dosin2005@dosin-china.com Web: http://www.dosinconn.com TEL: (0086) 769-81153906 FAX: (0086) 769-81875836	
Name: SMA JACK		REV A	
SIZE A	Product NO. DOSIN-806-0247	SHEET: 1 OF 1	
DateTime 2017/3/14	CAD FILE H/company drawings/BD		

Product NO. DOSIN-806-0247			
REV	DESCRIPTION	DWN	DATE
A	First issue	Mr. chen	2016/12/23
		APPROVEN John kine	