

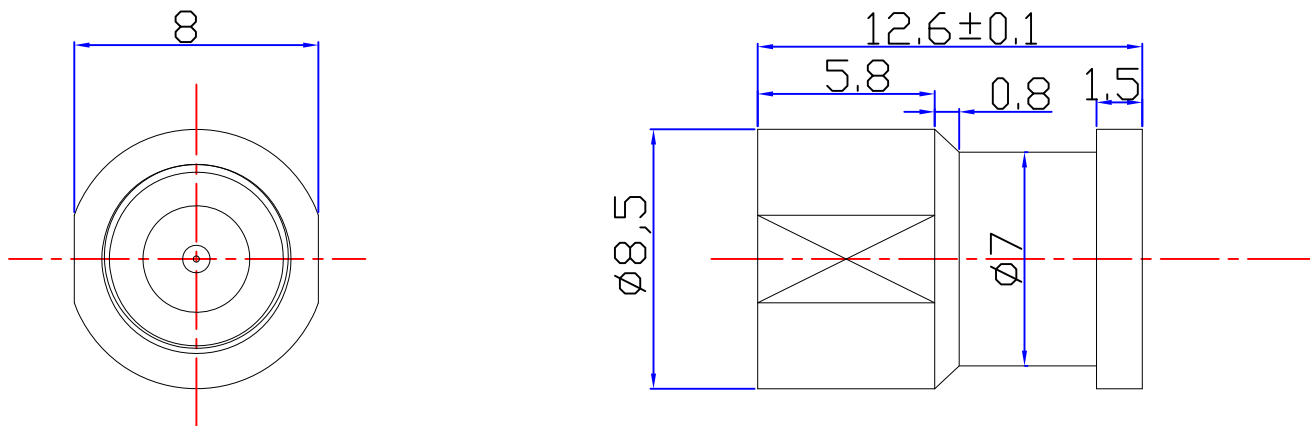

Product NO.		DOSIN-806-0240		
REV	DESCRIPTION	DWN	DATE	APPROVEN
A	First issue	Mr. chen	2016/11/11	John kine



Specifications:

IMPEDANCE: 50 Ohms
 Frequency range: 0~6GHZ
 VSWR: 1.5MAX
 Working voltage: 500V rms @ sea level
 Insulation resistance: 5000 Ohms min
 Temperature range: -65°C TO +165°C
 Relative temperature: ≤95% (40° C ± 2° C)

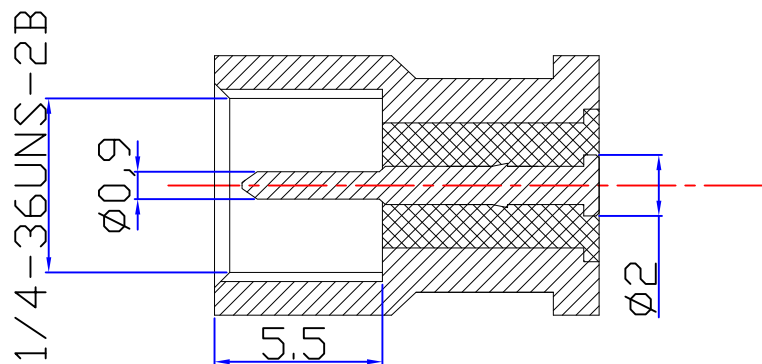

8				
7				
6				
5				
4				
3	CONTACT PIN	BRASS	GOLD	1
2	INSULATOR	TEFLON	NATURAL	1
1	BODY	BRASS	NICKEL	1
	DESCRIPTION	MATERIAL	FINISH	QTY

NOTE:	
DRAWN	2016/11/11
Zelin.chen	
CHECKED	
APPROVALS	11/11.2016
John	

Tolerance	X. ±0.15 X.X ±0.10 X.XX ±0.05 Angular ±5°
View	
UNIT	MM
SCALE	1:1

DOSIN -RF CONNECTOR *Dosin Industrial (HK) Co., Ltd*
 东莞市德索五金电子制品有限公司
Dosin Hardware Electronics Co., Ltd

E-mail: dosin2005@163.com
 dosin2005@dosin-china.com
 Web: http://www.dosinconn.com
 TEL: (0086) 769-81153906
 FAX: (0086) 769-81875836

Name: **对讲机天线座**

SIZE	Product NO.	REV
A	DOSIN-806-0240	A

DateTime: 2016/09/08
 CAD FILE: H/company drawings/BD
 SHEET: 1 OF 1