

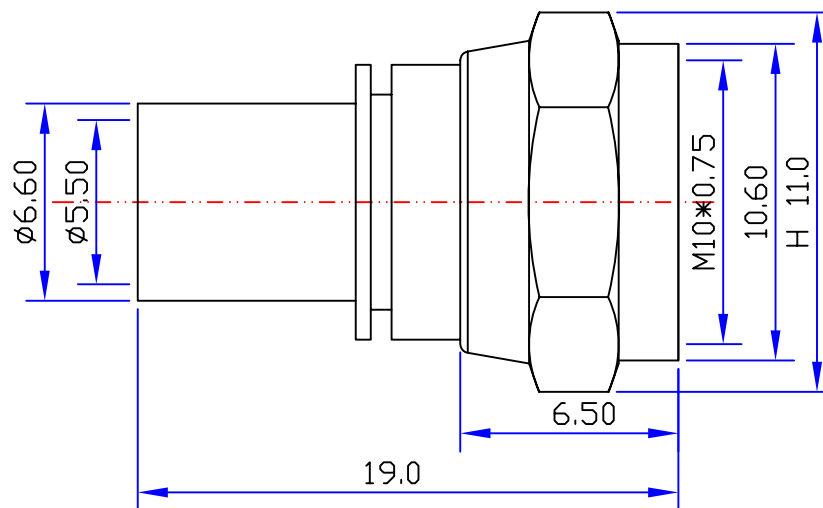

Product NO.		DOSIN-803-0020		
REV	DESCRIPTION	DWN	DATE	APPROVEN
A	First issue	Mr. Wang	2013/03/30	John kine
B				

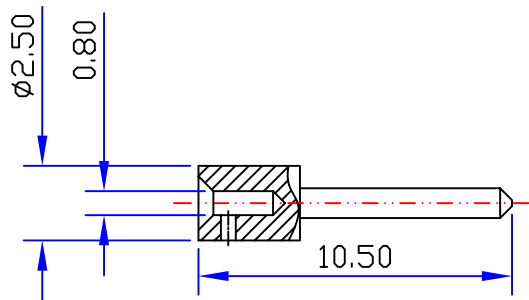

SPECIFICATIONS:

Impedance: 75 Ohms
 Frequency Range: DC~3G
 VSWR: 30dB Return loss @ 1GHZ
 Working Voltage: 15 watts continuous
 Insulation Resistance: 5000 Ohms min
 Temperature Range: -40°C TO +60°C
 Drawings products are in line with ROHS standards

1	Shell	Brass	NI:80-120u"
2	Body	Brass	NI:80-120u"
3	Contact pin	Brass	NI:80-120u"
4	Insulation	Pom	None
5			
6			
7			
8			
9			
10			
NO	Component Number	Material	Finish

NOTE:	
DRAWN	2013/03/30
Zelin.Zhang	
CHECKED	
APPROVALS	
John Kine	30/03.2013

Tolerance	X. ±0.15 X.X ±0.10 X.XX ±0.05 Angular ±5°
View	
UNIT	MM
SCALE	1:1

Dosin -RF CONNECTOR
Dosin Industrial (HK) Co. Ltd
 东莞市德索五金电子制品有限公司
Dosin Hardware Electronics Co., Ltd

E-mail: dosin2005@163.com
 dosin2005@dosin-china.com
 Web: http://www.dosinconn.com
 TEL: (0086) 769-81153906
 FAX: (0086) 769-81875836

Name: F Plug Stright For RG59

SIZE	Product NO.	REV
A	DOSIN-803-0020	A

DateTime: 2013/03/30
 CAD FILE: H/company drawings/BD
 SHEET: 1 OF 1