

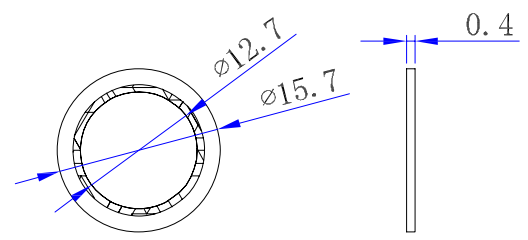

Product NO.		DOSIN-802-0013		
REV	DESCRIPTION	DWN	DATE	APPROVEN
A	First issue	JIM	2012/11/02	John kine

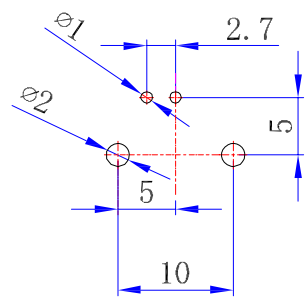
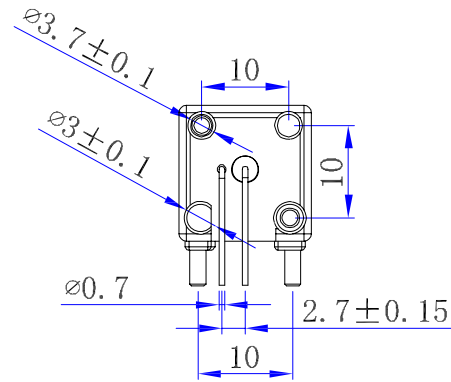
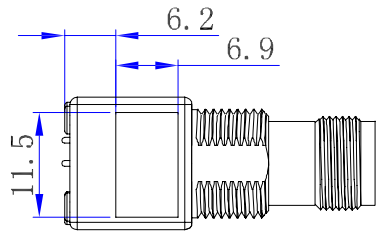
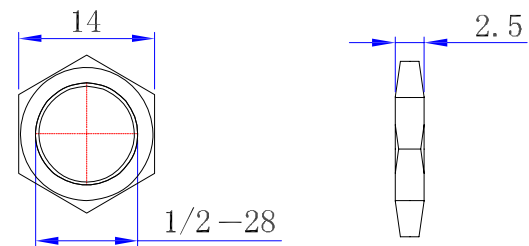
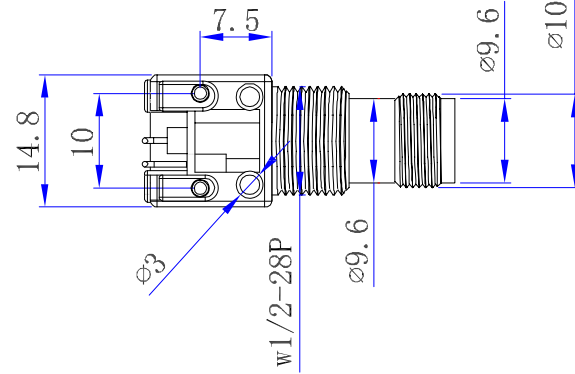
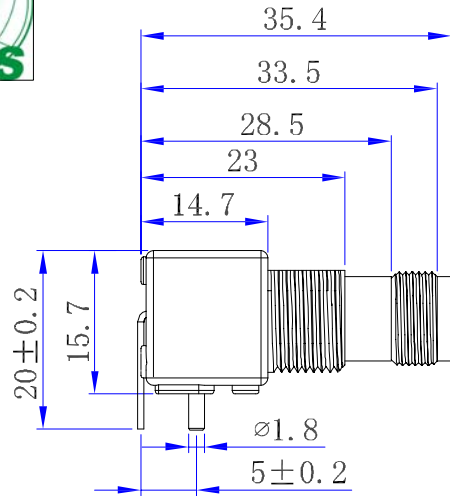

Specifications

Frequency Range:DC~3G
 VSWR:1.3MAX
 Working Voltage:500V rms @ sea level
 Insulation Resistance:5000 Ohms min
 Temperature Range:-55°C TO +155°C
 Relative Temperature:≤95%(40° C±2° C)
 Drawings products are in line with ROHS standards

NOTE:

DRAWN	2012/11/10
CHECKED	
APPROVALS	12/04.2012

John Kine

Tolerance	0-6 ±0.15 6-30 ±0.20 30-120 ±0.5 Angular ±2°
View	
UNIT	MM
SCALE	1:1

Dosin Industrial(H.K)Co.Ltd 东莞市德索五金电子制品有限公司 Dosin Hardware Electronics Co.,Ltd		E-mail: dosin2005@163.com dosin2005@dosin-china.com Web: http://www.dosinconn.com TEL: (0086)769-81153906 FAX: (0086)769-81875836	
Name:		TNC CONNECTOR DNN	
SIZE	Product NO.	REV	
A	DOSIN-802-0013	B	
DateTime	CAD FILE	SHEET: 1 OF 1	
2012/11/02	D/company drawings/BD		

3	BODY	ZINC	NICKEL	1
2	INSULATOR	POM	WHITE	1
1	PIN	BRASS	GOLD	1
NO	DESCRIPTION	MATERIAL	FINISH	QTY